

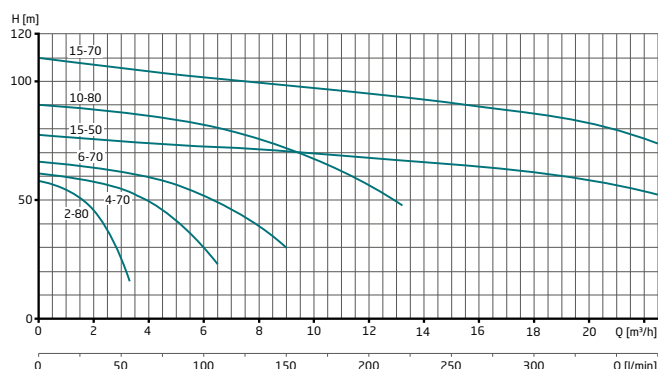

Characteristics

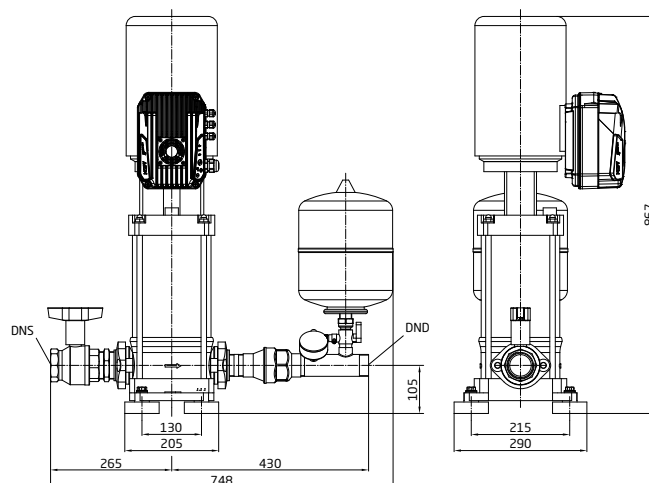

Dimensions



Drawing for AE-T 10-80; other types similar to illustration

Type	H	Type	H
AE-M (T) 2-80	669	AE-T 10-80	867
AE-M (T) 4-70	668	AE-T 15-50	1052
AE-M (T) 6-70	720	AE-T 15-70	1134

Technical data

Type	Inlet connection (Rp)	Outlet connection (R)	Power output P_2 (kW)	Input voltage	Rated current (A) 1 x 230 V	Input voltage	Rated current (A) 3 x 400 V	Approx. weight (kg)
AE-M 2-80	1 ¼	1 ¼	0.55	1~ 230 V	2.10	-	-	38.00
AE-M 4-70	1 ¼	1 ¼	1.10	1~ 230 V	4.00	-	-	41.00
AE-M 6-70	1 ¼	1 ¼	1.50	1~ 230 V	5.50	-	-	43.00
AE-T 2-80	1 ¼	1 ¼	0.55	-	-	3~ 400 V	1.20	38.00
AE-T 4-70	1 ¼	1 ¼	1.10	-	-	3~ 400 V	2.30	41.00
AE-T 6-70	1 ¼	1 ¼	1.50	-	-	3~ 400 V	3.20	43.00
AE-T 10-80	1½	1½	3.00	-	-	3~ 400 V	5.80	64.00
AE-T 15-50	2	2	5.50	-	-	3~ 400 V	10.00	111.00
AE-T 15-70	2	2	7.50	-	-	3~ 400 V	13.30	122.00

Order information

Type	Article no.	Flow rate (m³/h)	Target pressure (bar)	Net RRP	Gross RRP
AE-M 2-80	561.0208.601	2.00	4.00	2,798.94 €	3,330.74 €
AE-M 4-70	561.0407.601	4.00	4.00	2,868.08 €	3,413.02 €
AE-M 6-70	561.0607.601	6.00	4.00	3,080.57 €	3,665.88 €
AE-T 2-80	561.0208.611	2.00	4.00	2,798.94 €	3,330.74 €
AE-T 4-70	561.0407.611	4.00	4.00	2,868.08 €	3,413.02 €
AE-T 6-70	561.0607.611	6.00	4.00	3,080.57 €	3,665.88 €
AE-T 10-80	561.1008.611	10.00	6.50	4,158.24 €	4,948.31 €
AE-T 15-50	561.1505.611	15.00	6.00	4,574.49 €	5,443.64 €
AE-T 15-70	561.1507.611	15.00	8.00	5,600.20 €	6,664.24 €

Warehouse goods, can be dispatched immediately